

# High Temperature Solar-Heated Reactors for Industrial Production of Reactive Particulates, SOLPART

*[www.solpart-project.eu](http://www.solpart-project.eu)*

**Starting date: 01.01.2016**

Call LCE-02-2015: Developing the next generation technologies of renewable electricity and heating/cooling

Renewable Heating and Cooling: Solar heating for industrial processes



High Temperature Solar-Heated Reactors for  
Industrial Production of Reactive Particulates



## **SOLPART Project Objective**

Develop, at a pilot scale, a high temperature (800–1000 °C) 24 h/day solar process suitable for particle treatment in energy intensive non-metallic minerals' industries.

## **SOLPART Project Concept**

Supplying totally or partially the thermal energy requirement for  $\text{CaCO}_3$  calcination by solar heat, which is 60% of the total required energy in a cement plant and 100% in a lime plant.

Examining similar thermal applications for other non-metallic minerals, e.g. dolomite, phosphate, kaolinite, and others.

# Expected Results and Impact

- Demonstrate a **pilot scale solar reactor** (about 30 kW<sub>th</sub>) suitable for calcium carbonate decomposition and cement raw meal calcination (calcination reaction:  $\text{CaCO}_3 = \text{CaO} + \text{CO}_2$ ).
- Simulate at prototype scale a 24 h/day industrial process (TRL 4–5) thereby requiring a **high temperature (about 900 °C) particle transport and storage system**.
- Reduce the CO<sub>2</sub> emission by 40% in the lime and cement industry and by 100% if CO<sub>2</sub> capture and sequestration is applied. Inject 60% solar energy in cement processing.
- Develop a solar technology able to treat particles to about 900 °C and apply it to various minerals.



High Temperature Solar-Heated Reactors for  
Industrial Production of Reactive Particulates



# SOLPART Project Partners

Participant No *	Participant organisation name	Short name	Organization type	Country
1	Centre National de la Recherche Scientifique	CNRS	Research organization	FR
2	CEMEX	CEMEX	Industry	CH
3	Deutsches Zentrum für Luft- und Raumfahrt EV	DLR	Research organization	DE
4	Abengoa Research	ABENGOA	Industry	SP
5	University Manchester	UMAN	High education	UK
6	European Powder & Process Technology	EPPT	SME	BE
7	COMESSA	COM	SME	FR
8	EURONOVIA	EURONOVIA	SME	FR
9	New Lime Development	NLD	SME	BE
10	Université Cadi Ayyad (& OCP as third party)	UCA	High education	MA



# Lab-scale Solar Reactor Development and Testing

Shallow, cross-flow  
fluidized bed (patent  
Pending)

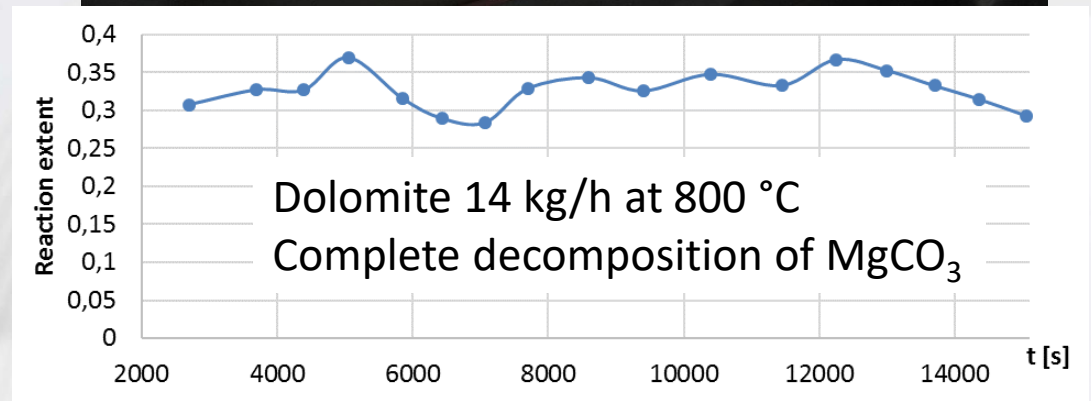
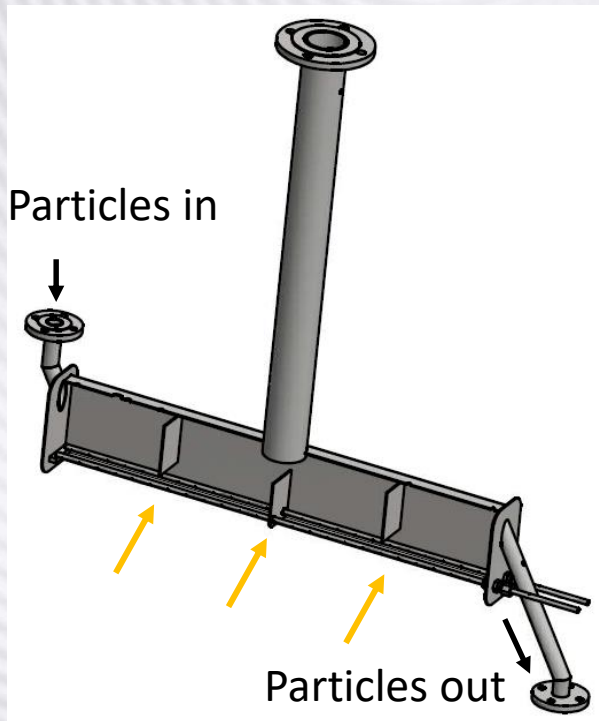
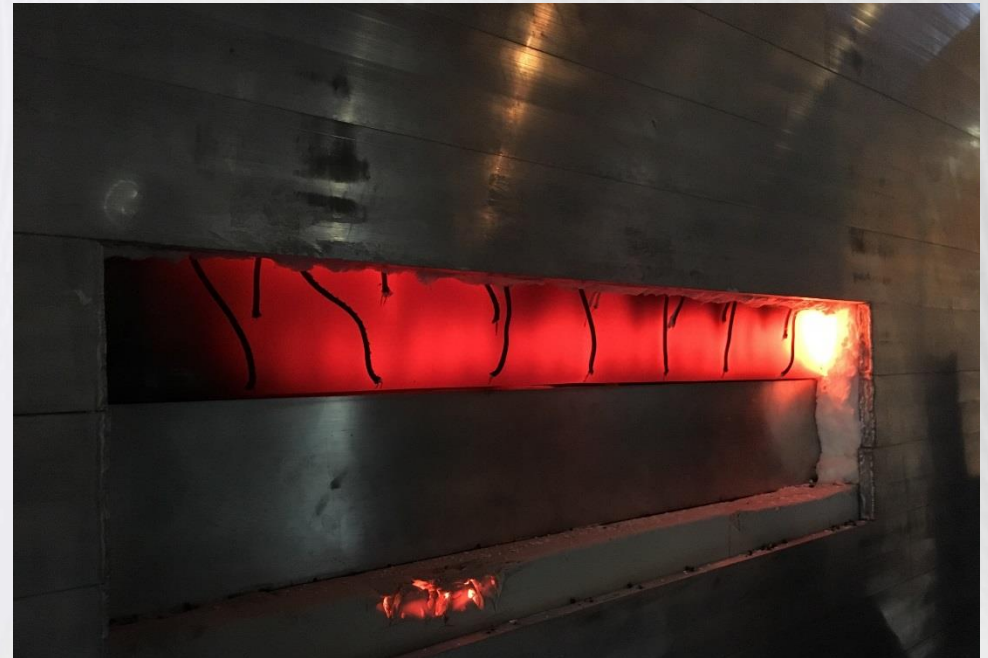

High Temperature Solar-Heated Reactors for  
Industrial Production of Reactive Particulates



# Lab-scale Solar Reactor Development and Testing

## Rotary Kiln (DLR)

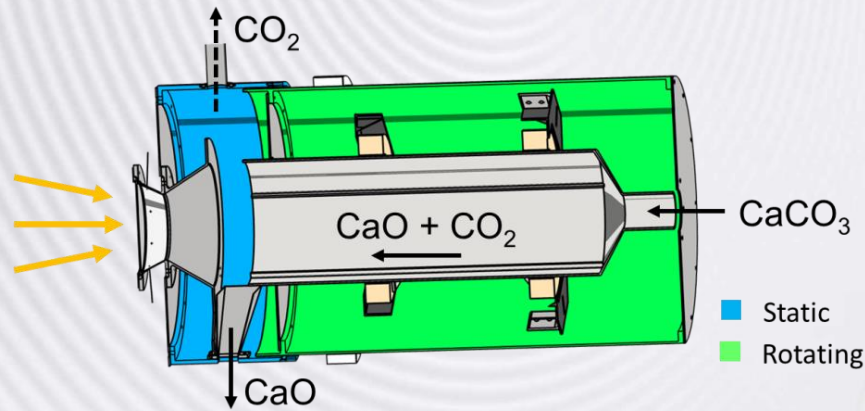

Cement raw meal 11.4 kg/h at 890 °C  
Partial decomposition (45%) of CaCO<sub>3</sub>

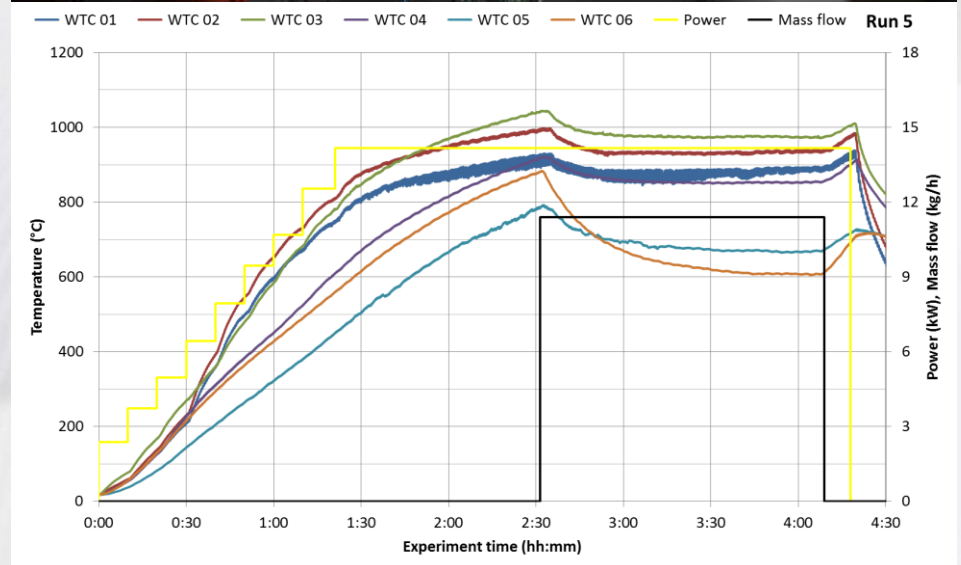

# Major Challenges and Barriers

- Develop solar reactors able to process continuously reactive particles with various size and reaction temperature.
  - Design and test conveying and storage systems at 900 °C.
  - Design a solar process that can be integrated in existing plants (cement, lime, phosphate).
- 
- ✓ High temperature materials
  - ✓ Residence time / reaction time
  - ✓ Dust formation and management
- 
- Scale-up to MW<sub>th</sub> production facility



High Temperature Solar-Heated Reactors for  
Industrial Production of Reactive Particulates



# Thank you for your kind attention

Jan Baeyens, EPPT, Solpart partner  
Co-inventor of the SCfFB